

JET

Series

Specifications



Fan type: In line centrifugal roof curb mounted with vertical discharge

Applications: Suitable for operation in highly corrosive applications such as laboratory exhaust or the chemical industry.

Housings: PP



Single back strong high density UV treated and recyclable polypropylene (PPH) with no air leakage. All fan mounting hardware in stainless steel.

Wheels: PP

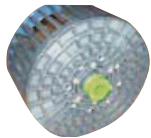

Forward curved centrifugal type impeller made of injection molded PPH. Fan wheel supplied with motor shaft bushing and hub cap constructed of PPH. Wheels electronically and dynamically balanced to ISO 1940.

Motors



Direct drive, asynchronous, single or three phase, IP55. Single speed: three phase 230/400V-50/60 Hz, single phase 230V-50Hz. Explosion proof motors available on request. Motor is outside the corrosive airstream and accessible by removal of outer housing. Three phase motors speed adjustable by variable frequency inverter drive..

ATEX



SEAT Series Fans are also available in ATEX Zone II, known outside Europe as explosion proof category 3 G execution in accordance with ATEX directive 94/9/CE. ATEX declaration of conformity available on our web site www.seat-ventilation.com. The performances curves of explosion proof fans are identical with the ones of the standard version.

Temperature resistance

PPH casing and wheel recommended up to 80°C.

Performance

Fan performance based on tests conducted in accordance with AMCA 210-85 and ISO 5801.

Warranty

SEAT VENTILATION warrants its equipment to be free from defects in workmanship and material under normal use and service for two years after shipment. Warranty is void if damage results from improper wiring or installation



Electrical data and weight*

	RPM (T/min)	(kW)	(V)	AMP draw (A)	Weight (Kgs)
Single phase					
JET 20	1500	0,25	230	2,5	19,50
	3000	0,75	230	5,4	25,20
JET 25	1500	0,37	230	3,1	25,50
JET 30	1500	1,50	230	9,2	40,15
Three phase					
JET 20	1000	0,18	230/400	1,5/0,85	22,80
	1500	0,25	230/400	1,7/0,96	22,80
	3000	0,75	230/400	3,2/1,9	24,00
	3000	1,10	230/400	4,7/2,7	25,90
JET 25	1500	0,37	230/400	2,1/1,2	25,50
	1500	0,55	230/400	3,1/1,8	28,00
	3000	2,20	230/400	8,8/5,1	35,00
JET 30	1000	0,55	230/400	3/1,8	38,2
	1500	1,10	230/400	6,4/3,7	43,2
ATEX 					
JET 20 ATEX	1500	0,18	230/400	0,97/0,56	20,50
JET 25 ATEX	1500	0,37	230/400	1,7/1,1	30,00
JET 30 ATEX	1500	1,10	230/400	4,4/2,55	61,80

*Tabulated current values are approximate and depend on make and model of the motor.

Assembly drawings

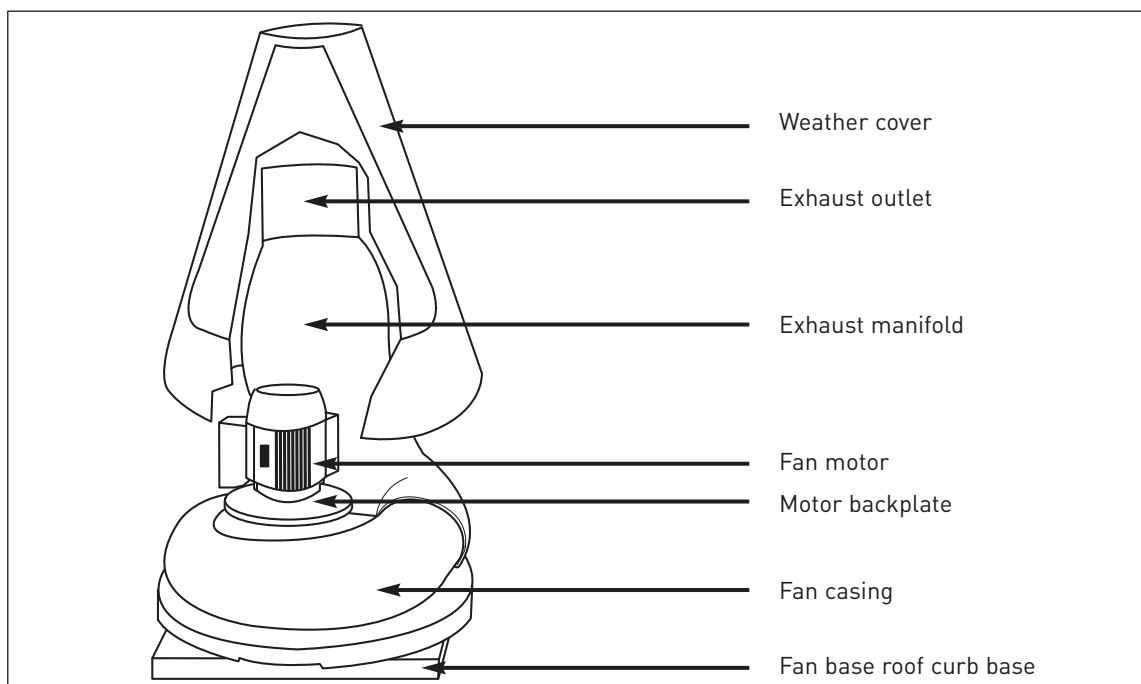

JET 20

JET Series

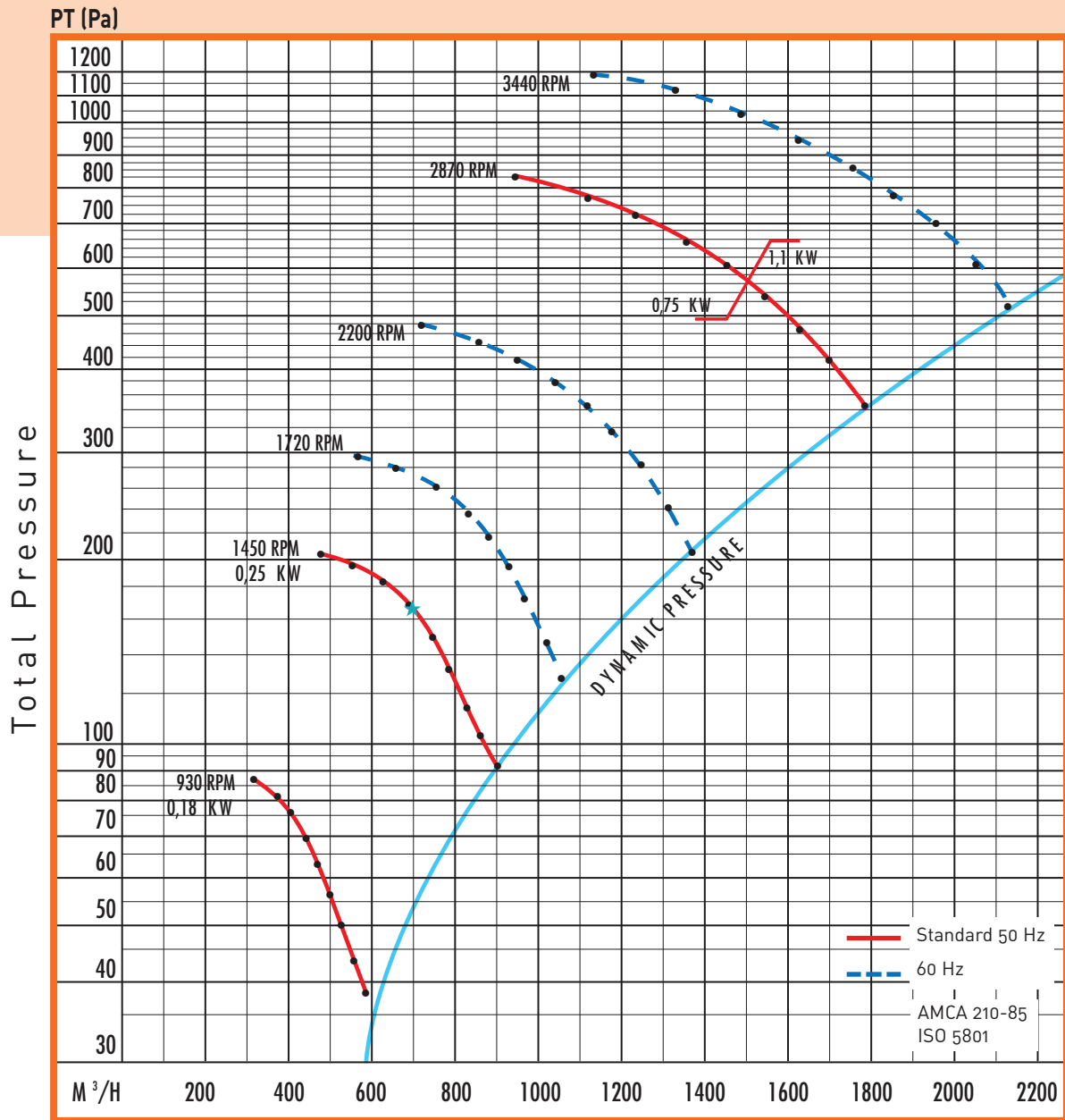

Free inlet/Free outlet
Noise level test type A.
Visit our website for details.

n (T/min) R.P.M.	LWA dB(A)
950	60,3
★ 1450	70,3
2900	85,1



JET 20

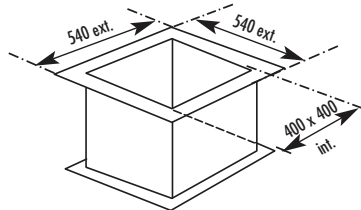
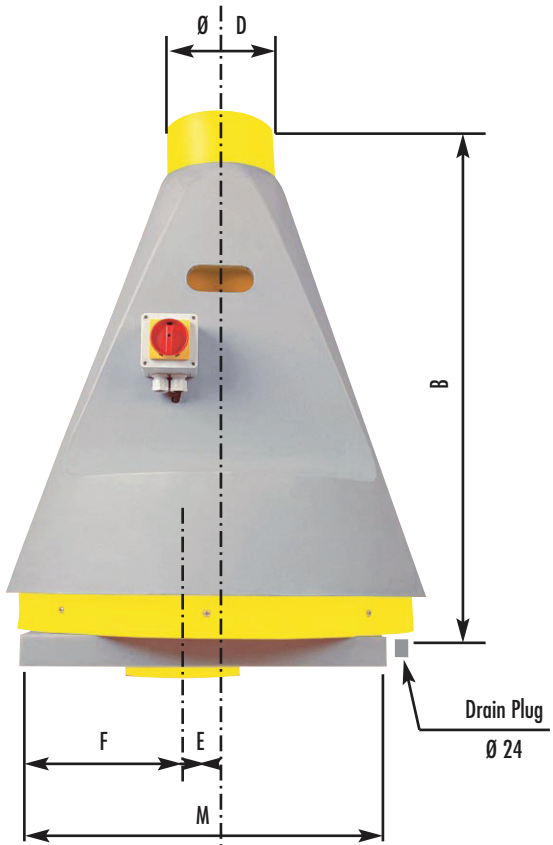

Roof curb sizing for guidance only

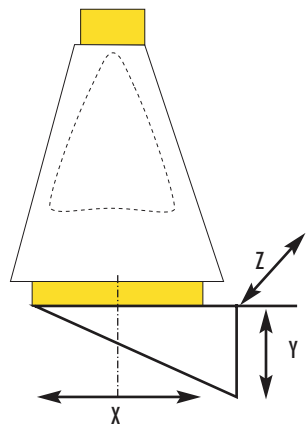
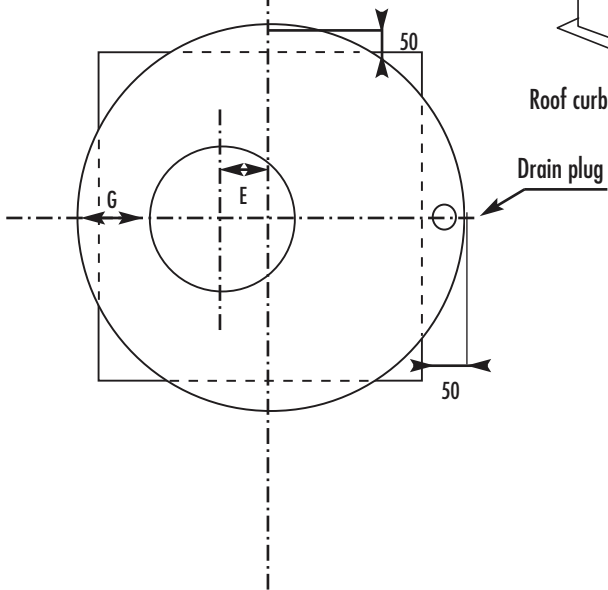

Option :
Wall metal bracket

Dimensional data (mm)										
A	B	Ø D	E	F	G	H	X	Y	Z	M
600	800	160	50	250	160	70	280	350	400	540-540 in.



JET 25

JET Series

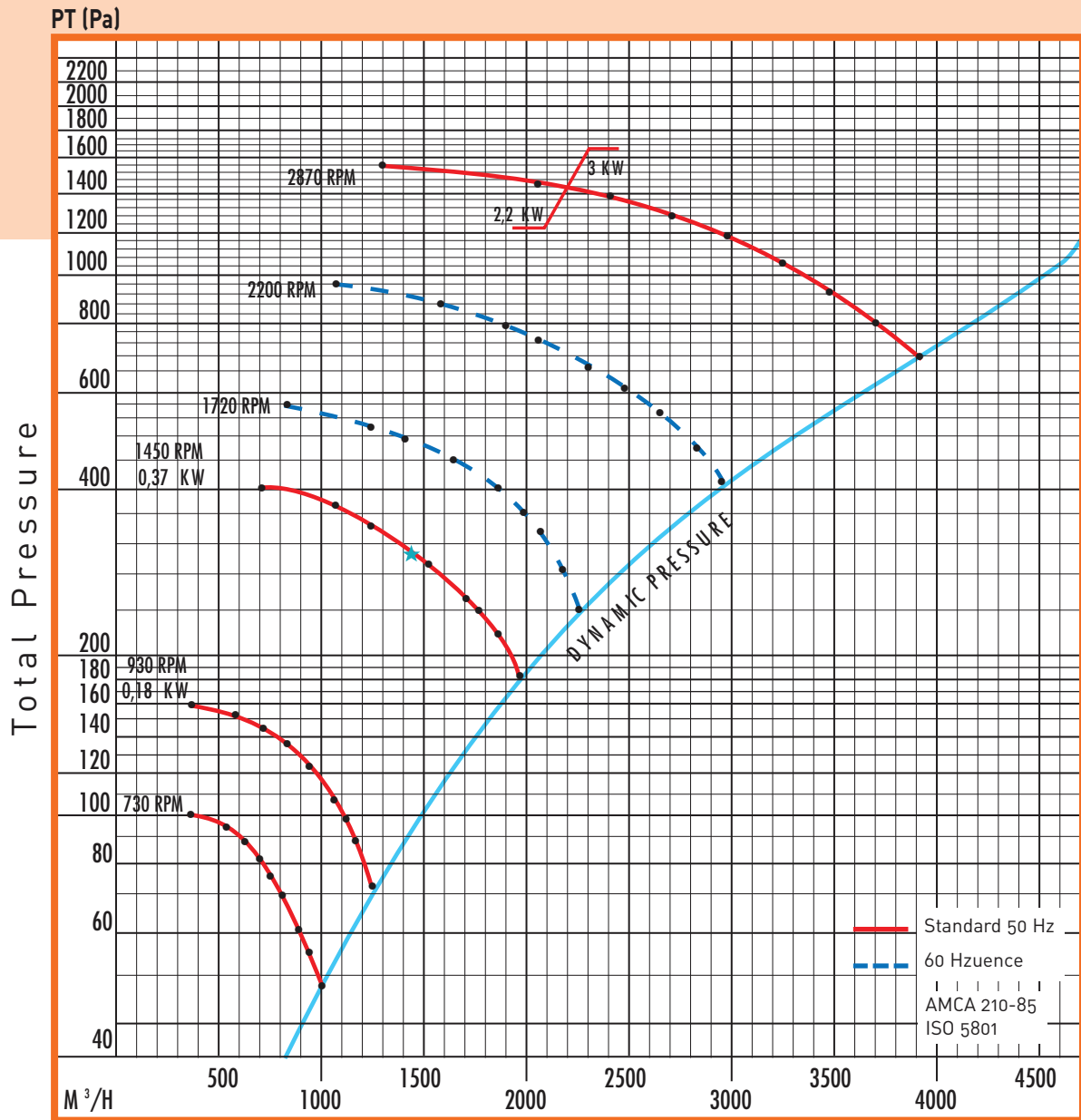

Free inlet/Free outlet
Noise level test type A.
Visit our website for details.

n (T/min) R.P.M.	LWA dB(A)
950	66,2
★ 1450	76,0
2900	90,6

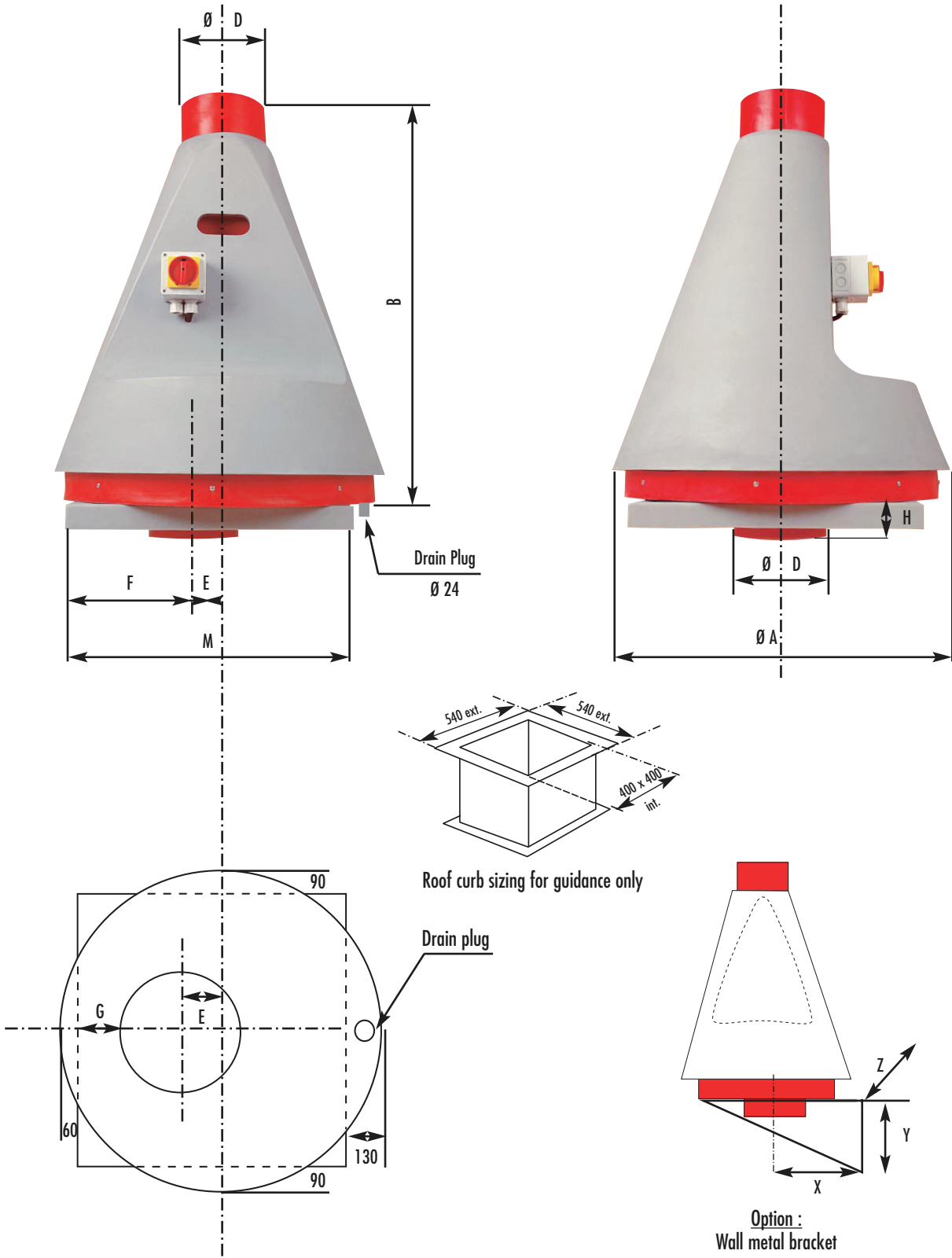

Dimensional data (mm)										
A	B	$\emptyset D$	E	F	G	H	X	Y	Z	M
735	930	200	60	240	145	70	330	350	510	540-540 in.



JET 30

JET Series

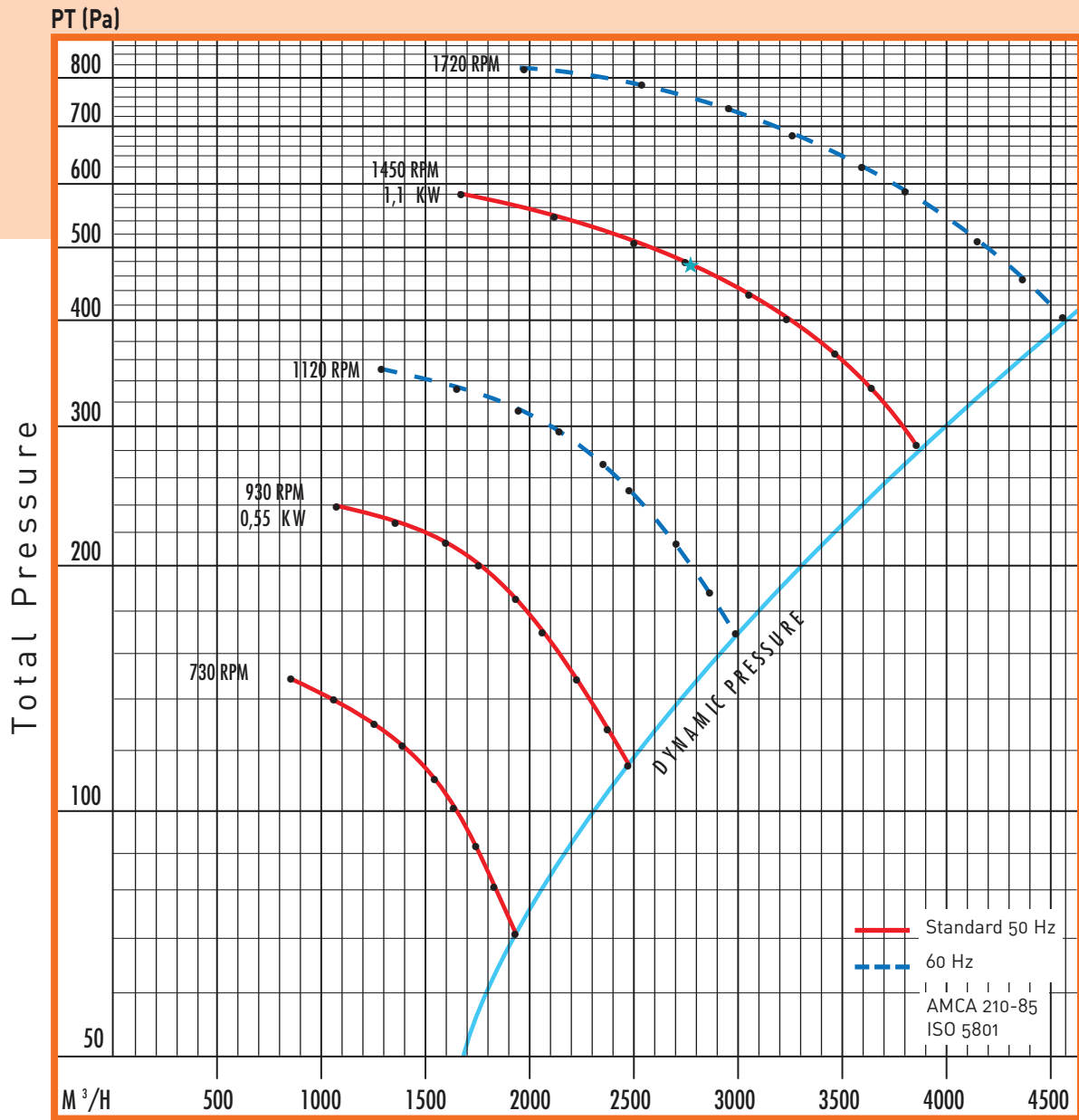

Free inlet/Free outlet
Noise level test type A.
Visit our website for details.

n (T/min) R.P.M.	LWA dB(A)
950	73,1
★ 1435	82,8

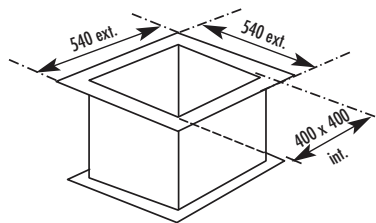
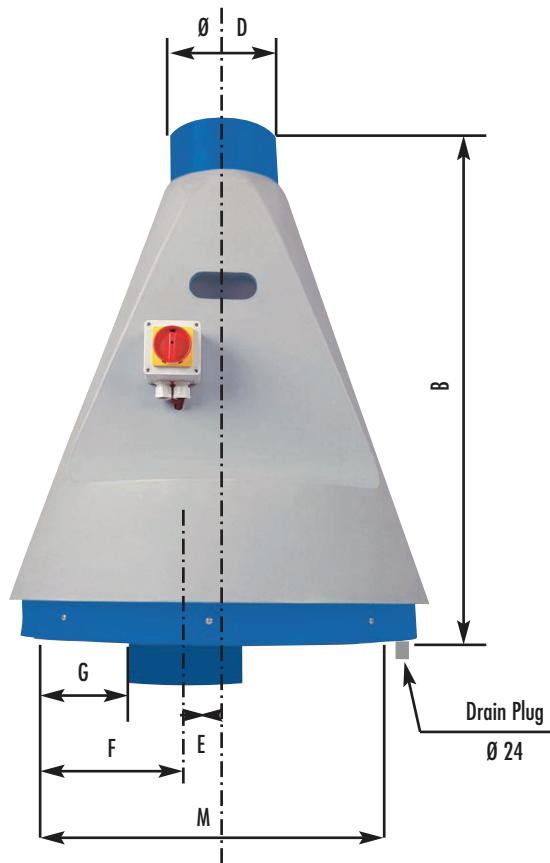

Roof curb sizing for guidance only

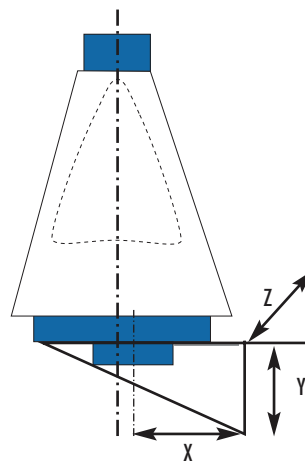

Option :
Wall metal bracket

Dimensional data (mm)											
A	B	Ø D	E	F	G	H	G'	X	Y	Z	M
880	1040	250	70	200	75	70	130	400	400	600	540-540 in.



JET 30

